

XRT83SL38/L38 OCTAL LONG HAUL, SHORT HAUL LIU MAIN INTERFACE

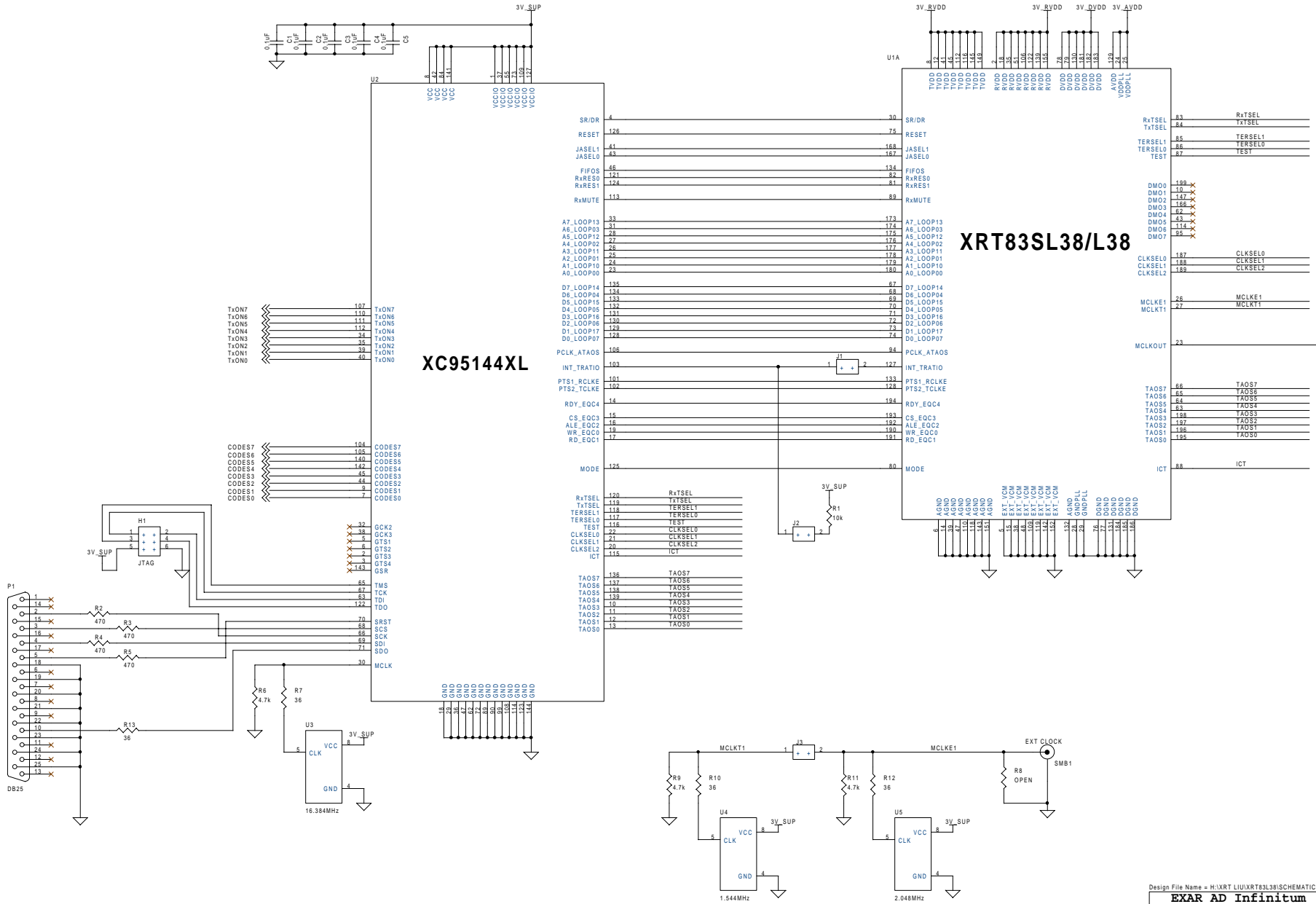

XRT83SL38/L38

XC95144XL

Design File Name = H:\XRT LIU\XRT83SL38\SCHEMATIC\XRT83SL38 EVAL.DSN

| | | |
|--------------------------|---|--------------|
| EXAR AD Infinitum | | |
| File | XRT83SL38/L38 | |
| Size | Document Number | Rev |
| C | XRT83SL38/L38 LONG HAUL, SHORT HAUL LIU | D |
| Date: | Tuesday, September 17, 2002 | Sheet 1 of 3 |

POWER CIRCUITRY

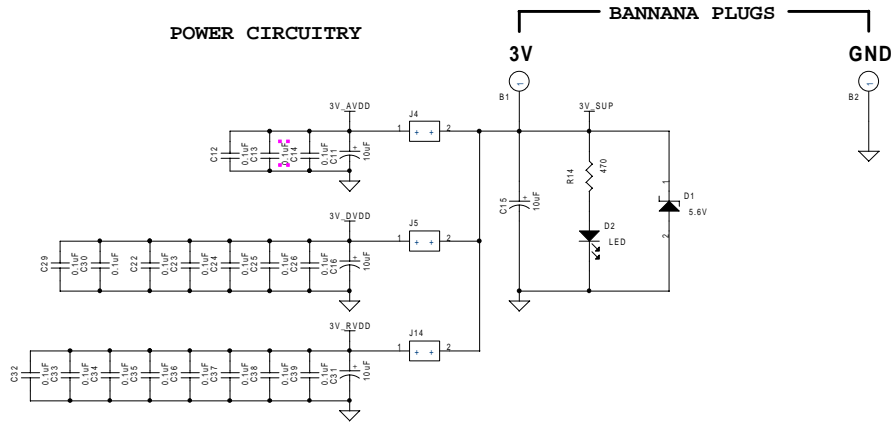

GROUND POINTS

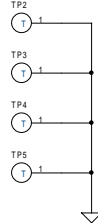

MOUNTING HOLES

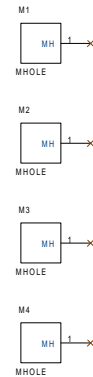

LIU TRANSMIT AND RECEIVE

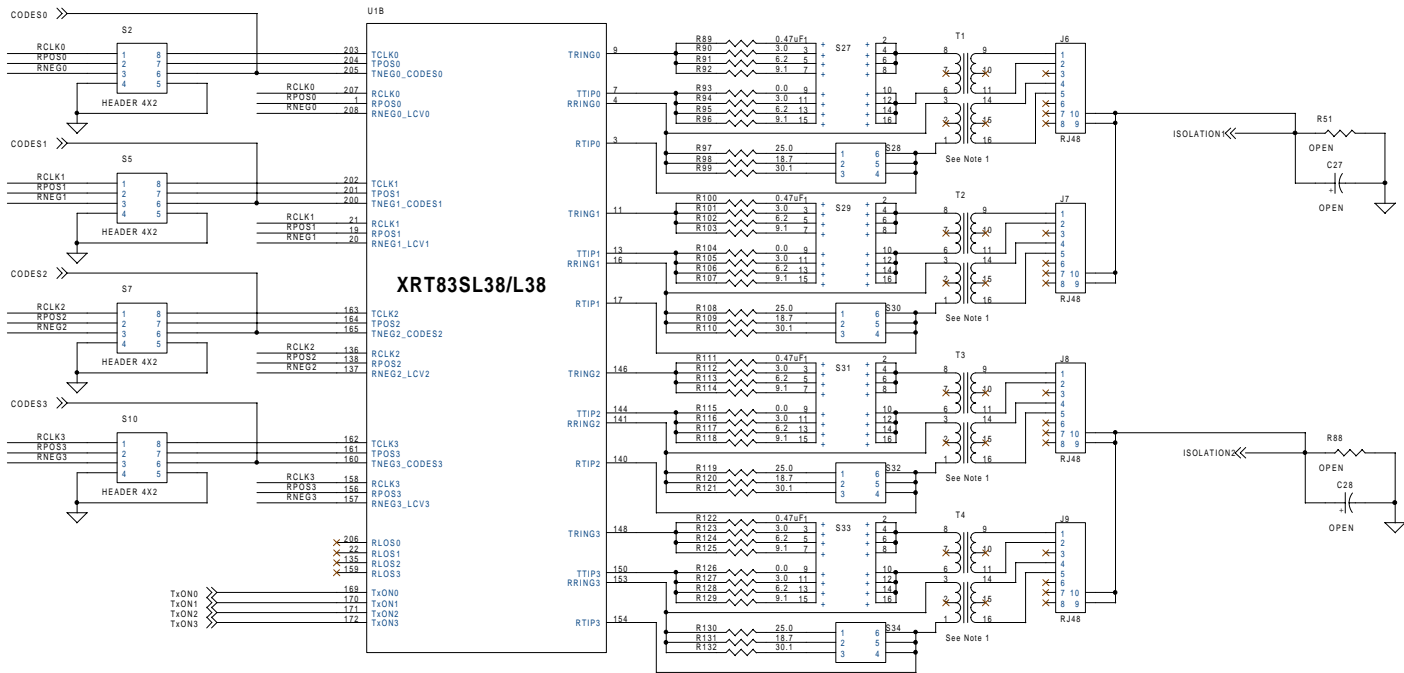

Tx=1:2, Rx=1:1
Note 1: Transformer Selection
 TRANSPOWER SMD606-05
 HALO TG74-1505N1

Design File Name = H:\XRT LIU\XRT83L38\SCHEMATIC\XRT83L38 EVAL.DSN

| | | |
|--------------------------|---|--------------|
| EXAR AD Infinitum | | |
| File | XRT83SL38/L38 | |
| Size | Document Number | Rev |
| C | XRT83SL38/L38 LONG HAUL, SHORT HAUL LIU | D |
| Date: | Tuesday, September 17, 2002 | Sheet 2 of 3 |

LIU TRANSMIT AND RECEIVE

